

DuoFLO® Filter Systems

Filter Cartridge Benefits... ...Filter Bag Economy



- Easily retrofits standard bag filter housings
- Provides up to 4 times or more life than conventional bag filters
- Eliminates filter media rupture, contaminant by-pass and unloading
- Simplifies filter installation, removal, and disposal
- Reduces hold-up volume by up to 67% or more



CUNO DuoFLO® Filter System

The patented CUNO DuoFLO filter system* is an advanced proven alternative to the use of standard bag filters. Developed using CUNO's extensive depth filtration experience, the DuoFLO filter features a true graded-porosity media structure and a 62 % increase in filter surface area. Compared to conventional felt filter bags, DuoFLO filters provide:

- up to 4 times or more the service life
- superior contaminant removal efficiency
- enhanced flow per filter element
- reduced losses associated with frequent filter change-outs (production downtime, disposal, and labor costs)

The DuoFLO filter will easily retrofit most existing bag filter housings. To take advantage of the DuoFLO system in applications where bag filter housings are currently in use, simply remove the existing bag support basket, replace it with a DuoFLO support basket, and insert the DuoFLO filter. For new installations, CUNO offers a full line of DuoFLO filter housings (page 5).



The DuoFLO Filter System - A Unique Design

The DuoFLO element is comprised of two cylinders bonded to a top plate and a lower seal plate. As shown in Figure 1, the fluid enters the top of the filter through flow channels located in the DuoFLO filter top plate. The fluid flows between the inner and outer media cylinders, and then passes through the media and support basket into the clean chamber of the filter housing.

The DuoFLO design incorporates an innovative new geometry of both filter element and restrainer basket which provides 100% 3 dimensional support of the DuoFLO media. This eliminates the potential for filter element rupture and the resulting gross contamination of the downstream effluent with previously removed particles. The unique design of the DuoFLO element also reduces filter element hold-up fluid volume by 67% compared to conventional bags, minimizing worker exposure to process fluids.

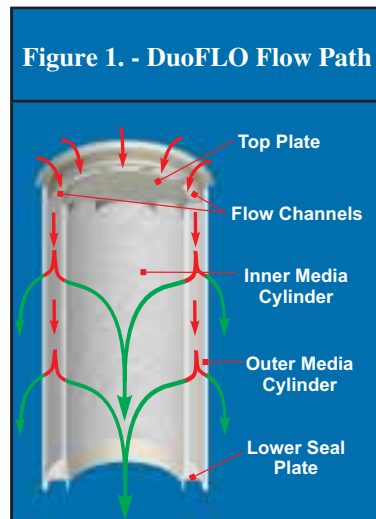

Features	Benefits
<ul style="list-style-type: none"> ■ Unique filter design combining a graded-porosity media with 62% greater filter surface area 	<ul style="list-style-type: none"> ■ Longer Service Life – up to 4 times or more that of conventional felt filter bags
	<ul style="list-style-type: none"> ■ Reduced Filter Usage - minimizes product loss, labor, disposal costs, and operator exposure
	<ul style="list-style-type: none"> ■ Increased productivity - less down time for filter change-out
<ul style="list-style-type: none"> ■ Hold-up volume reduced by 67% compared to conventional bag filters. 	<ul style="list-style-type: none"> ■ Reduced product loss & related disposal costs
	<ul style="list-style-type: none"> ■ Used element retains less fluid, making it lighter weight for easier removal
	<ul style="list-style-type: none"> ■ Eliminates displacement balloons and associated spillage during change-out
<ul style="list-style-type: none"> ■ 100%, downstream support of the filter element 	<ul style="list-style-type: none"> ■ Eliminates filter rupture, contaminant bypass and unloading
	<ul style="list-style-type: none"> ■ Allows operation to higher differential pressures before filter change-out
<ul style="list-style-type: none"> ■ Superior flow characteristics 	<ul style="list-style-type: none"> ■ Maximizes utilization of filter surface area and maintains low operating pressure drop
	<ul style="list-style-type: none"> ■ Reduces flow per unit area (flux) for improved effluent quality

* US Patent Numbers 6,030,531, 6,238,560, 6,511,598, 6,706,198, 6,712,967, and other US and foreign patents pending

DuoFLO® Elements Provides Superior Service Life

CUNO utilizes state-of-the-art technology to produce the DuoFLO filter element optimizing both performance and filtrate quality to ensure customer satisfaction. DuoFLO filter elements are sized to replace conventional # 1 and # 2 bag filters and are available in both polypropylene and polyester materials (including 21 CFR listed materials) with nominal ratings from 1 to 200 micron.

Greater Media Surface Area

The DuoFLO filter design provides an increase in filter surface area of 62% when compared to commonly used #1 and #2 bag filters. This additional surface area provides the following benefits

- *Lower flux (flow rate per unit area):* Since filter life is inversely proportional to flux, reducing the flux by 50% can achieve up to a three-fold increase in filter life. Additionally, lower flux improves the retention efficiency of the element.
- *Lower initial pressure drop:* This increases the time before the recommended change-out pressure is reached

Greater Contaminant Holding Capacity

DuoFLO filters are offered in a graded porosity filter media where two media layers of different porosities are combined. The result is superior contaminant holding capacity. The added capacity is achieved by removing the larger contaminants in the first layer and the finer contaminants in the tighter, downstream layer (see

Figure 2. - DuoFLO Graded Porosity Media

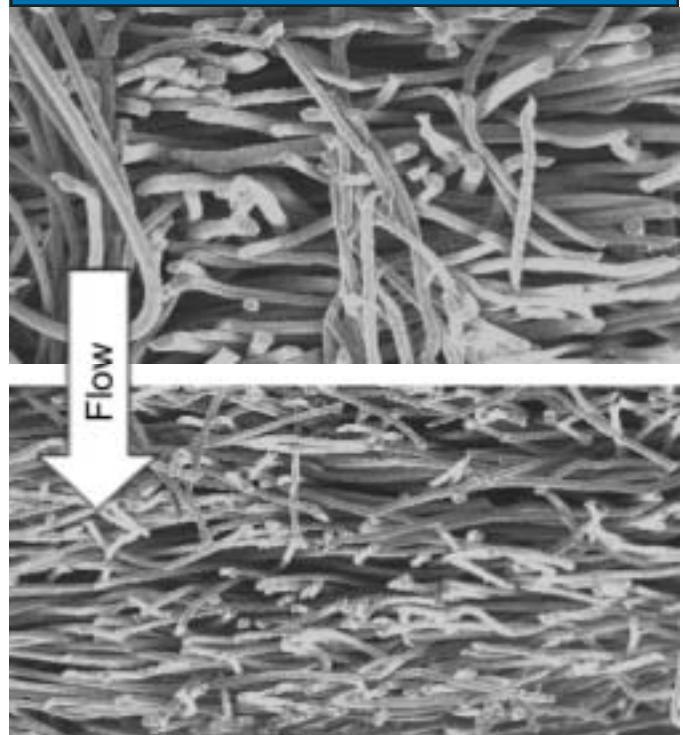
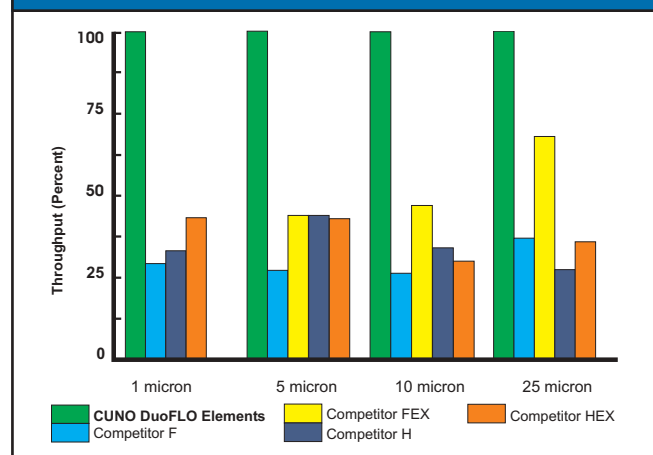

Figure 2). The configurations of each nominally rated filter media have been optimized to achieve the longest service life. Media Migration is eliminated by thermally bonding the exterior surface of the downstream media layer.

Superior Filter Service Life

Extensive testing, supported by field results, has demonstrated the superior life advantage achieved by DuoFLO elements while obtaining superior efficiencies. As shown in Graph 1, DuoFLO elements provide for up to 4 times the throughput compared to equivalently rated conventional bag filters (the life of the filters were measured to the same terminal differential pressure).

Graph 1. - Service Life Comparison for DuoFLO Elements and Conventional Bag Filters*



* Polypropylene media

DuoFLO[®] Filter Elements

Simple Filter Removal - Simply insert the CUNO removal tool into the top plate and lift the filter from the housing.



Reduced Hold-Up Volume - A 67% reduction in hold-up volume significantly decreases lost product and disposal costs.

Size	Hold-Up Volume (gallons)
#2 DuoFLO	1.4
#2 Standard bag	4.3

Easy Filter Installation - The DuoFLO filter element is a rigid cylinder that easily slides into the support basket.

Graded Porosity Media - DuoFLO media consists of 2 layers. The first layer or upstream zone is "open" to remove the larger contaminant while the downstream zone is "tighter" to remove the smaller contaminant. This design provides greater contaminant holding capacity and longer life than conventional single layer media.

Increased Surface Area - The unique design provides 62% more area than typical bag filters for longer life and fewer filter change-outs.

Size	Filter Area (ft ²)
#2 DuoFLO	6.7
#2 Standard Bags	4.1

Singed Media Surface - Many filter bags release fibers that end up in the filtered product. The DuoFLO filter media is thermally treated to eliminate loose fibers.

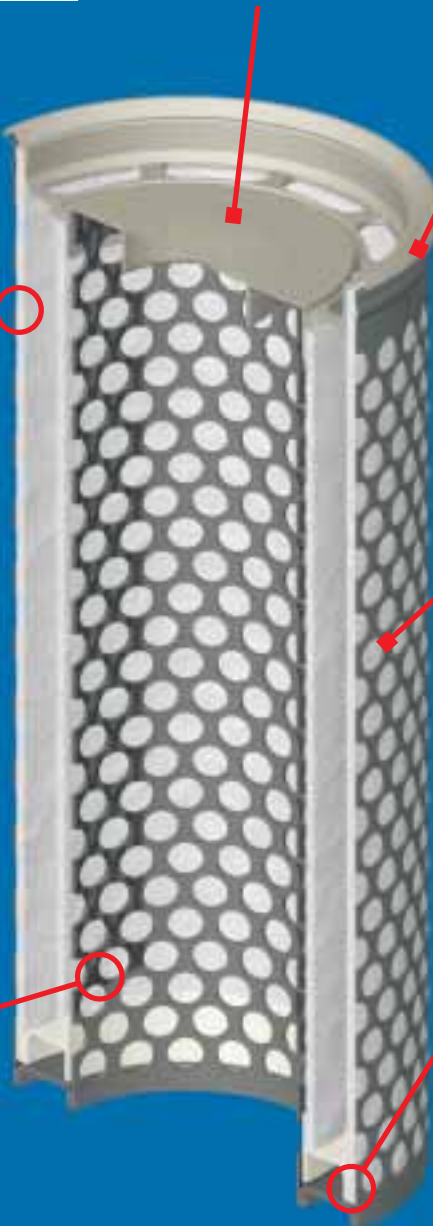

Superior Sealing Collar - Constructed from molded polypropylene or polyester with an advanced sealing lip that provides a dynamic spring-like seal, the DuoFLO design eliminates contaminant bypass.

Support Basket - Full Support of the filter element ensures filter integrity even under the most demanding conditions by eliminating the potential for media stretching which can open the pore structure and allow larger particles to pass.

Thermal Side Seam - Using advanced thermal sealing processes, the DuoFLO seam eliminates the problem of contaminants passing through large needle holes.

Integral Media to Plate Seal - an integral seal between the plastic components and the filter media is ensured by using state-of-the-art ultrasonic welding techniques.

The unique DuoFLO element design - 62% greater area and a unique graded-porosity media structure - provides a service life advantage of up to 4 times greater than conventional filter bags. Other features (sealing collar media treatment, thermal seaming, ultrasonic bonding of plastic parts to media) ensure that the DuoFLO filter is unsurpassed in quality and performance.

DuoFLO® Filter Specifications and Operating Parameters

Materials of Construction

Each grade of DuoFLO filter is manufactured from high performance fibers selected based on extensive media performance testing. No adhesives, binders, or silicone are used in the manufacturing process. The DuoFLO filter element is available in all-polypropylene, all-polyester, or polyester media with polypropylene lower seal and top plate construction.

Filter Element Size and Ratings Available

DuoFLO elements are available in sizes and ratings to replace standard #1 and #2 filter bags as follows:

DuoFLO Filter Element Specifications		
Dimension	DuoFLO Elements	
	#1 Size	#2 Size
Nominal Removal Ratings (microns)	1, 5, 10, 25, 50, 100, and 200*	
Filter Diameter (inches/cm)	7 / 17.8	
Filter Length (inches/cm)	14.3 / 36.3	27.8 / 70.6
Media Area (ft ² / m ²)	3.4 / 0.32	6.7 / 0.62
Hold Up Volume per Filter (Gallons/Liters)	0.7 / 2.6	1.4 / 6.2
* available in polyester only		

Flow Characteristics and Sizing Options

Flow vs. differential pressure for a DuoFLO #2 size element and support basket in water is depicted in Graph 2. A typical filter system is often sized for an initial differential pressure of 0.5 to 1 psi (0.04 to 0.07 bar). A lower flow rate per element typically extends the life of the filter system.

Operating Parameters by Material and Size				
Operating conditions	DuoFLO Polypropylene		DuoFLO Polyester	
	#1 Size	#2 Size	#1 Size	#2 Size
Maximum Operating Temperature (°F / °C)	180 / 82		300 / 149	
Maximum Recommended Flow Rate (gpm / lpm)	75 / 284	150 / 568	75 / 284	150 / 568
Maximum Forward Differential Pressure	35 psid @ 68°F (2.4 bar @ 20°C)			
Recommended Change-out Differential Pressure	20 psid (1.4 bar)			
Regulatory Status (See ordering guide)				
CFR Compliant	All component materials of the DuoFLO "PP" polypropylene element and "FE" polyester are listed for food contact per 21 CFR 177.1520.			

Chemical Compatibility Table		
Chemical	DuoFLO Material	
	Polypropylene	Polyester
Biological Agents	Excellent	Excellent
Mineral Acids	Excellent	Good
Organic Acids	Excellent	Excellent
Alkalies	Excellent	Poor
Oxidizing Agents	Fair	Fair
Organic Solvents	Fair	Good

The thermal and chemical resistance data presented in this brochure is for guidance only. Factors such as duration, degree of concentration of a substance in a fluid and temperature should also be considered. Thermal and chemical resistance should also be considered when choosing all materials exposed to fluids.

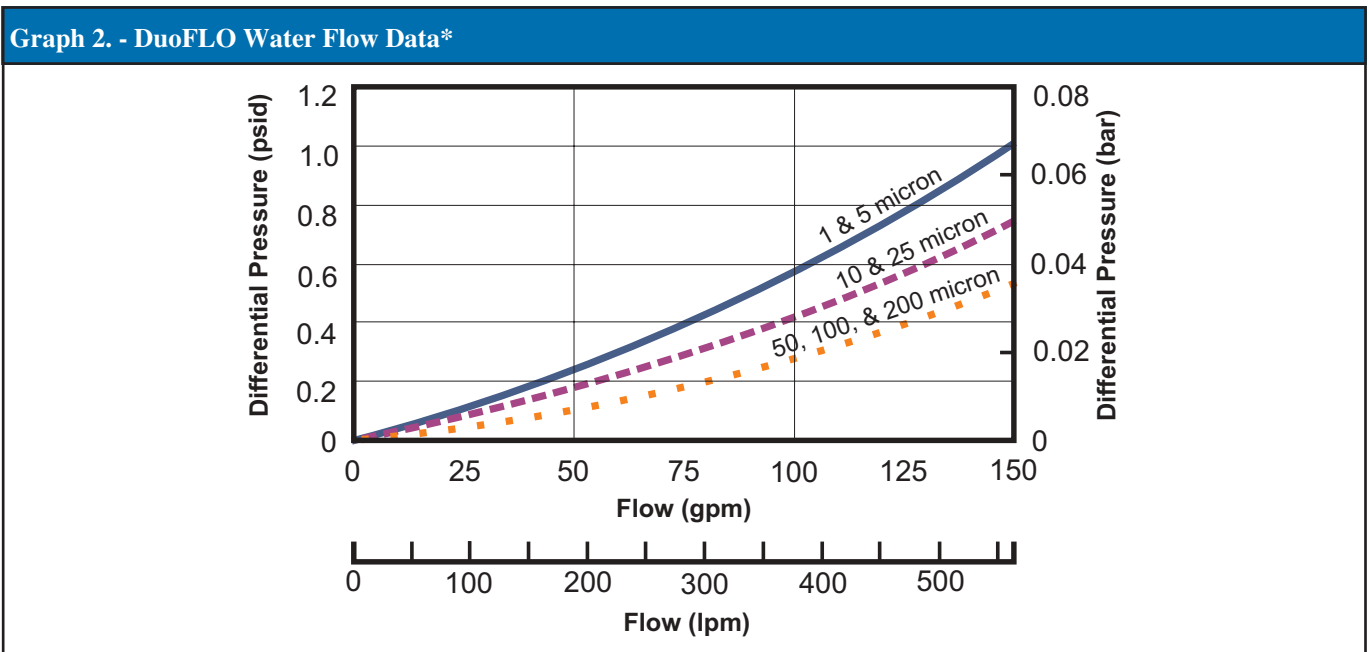

*#2 Size Element and Support Basket Pressure Drop Only, housing pressure losses are not included.

DuoFLO® Filter Housings



Patented* CUNO DuoFLO filter housings are designed and manufactured to economically meet demanding applications. The housings are available for #1 and #2 size DuoFLO filters and are constructed from 304 or 316L stainless steel. DuoFLO ASME code housings are designed, fabricated, and "U" stamped in accordance with ASME Section VIII, Division 1 for 150 psi @ 300°F*. For those applications not requiring AMSE code housings, an economical "DFN" version is available. A variety of inlet/outlet connection styles are available (see specification table below). In addition, custom designs are available on request.

The DuoFLO filter housing allows the user to realize all of the benefits of the DuoFLO filter element. A positive element sealing mechanism eliminates bypass of unfiltered fluid into the effluent stream. Since the DuoFLO filter element has more surface area and better flow characteristics, larger conventional bag housings can be eliminated in favor of smaller DuoFLO housings - reducing up-front capital expenditures and installation costs. In addition, the true "in-line" configuration of the inlet and outlet connections allow for installation without the additional piping and elbows required by conventional filter bag housings.

The unique flow configuration of the DuoFLO housing eliminates the "dirty chamber" that is common in bag filter housings, thus eliminating the potential for cross contamination of dirty fluid into the clean effluent during filter element change-out. DuoFLO housings incorporate a design that results in environmental, health, and safety benefit by allowing used DuoFLO filter element removal without the spillage of, or contact by the operator with, the process fluid.

Design Feature	Benefit
<ul style="list-style-type: none"> Positive element sealing mechanism 	<ul style="list-style-type: none"> Ensures no bypass of unfiltered fluid into the effluent stream.
<ul style="list-style-type: none"> No dirty fluid chamber 	<ul style="list-style-type: none"> Eliminates unfiltered fluid from contaminating the clean effluent side of the housing during filter change-out Reduces operator contact with the fluid
<ul style="list-style-type: none"> In-line piping configuration 	<ul style="list-style-type: none"> Significantly reduces installation time and costs Ease of piping for series or parallel installation
<ul style="list-style-type: none"> Excellent flow characteristics 	<ul style="list-style-type: none"> Reduces capital investment since fewer filter elements are required for a given flow rate

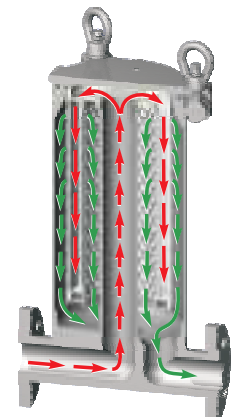

DuoFLO ASME Code Filter Housing Specification							
Size	Material	Connection Size/Type	Maximum Flow (gpm / lpm)	Maximum Pressure & Temperature	Housing Weight	Basket Weight	Leg Weight
#1	304 or 316L S.S.	2" ANSI or DIN Flange	75 / 284	150 PSI @ 300°F ◆ (10.4 bar @ 149°C)	80 lb/36.3 kg	8 lb/3.6 kg	4 lb/ 1.8 kg
#2		2" NPT or 2" BSPT _r	150 / 568		100 lb/45.4 kg	12 lb/5.4 kg	

DuoFLO DNF Filter Housing Specification						
Size	Material	Connection Size/Type	Maximum flow (gpm / lpm)	Maximum Pressure & Temperature	Housing Weight	Basket Weight
#1	304 or 316L S.S.	2" NPT	75 / 284	150 PSI @ 250°F ◆ (10.4 bar @ 121°C)	44 lb/20 kg	8 lb/3.6 kg
#2			150 / 568		56 lb/25 kg	12 lb/5.4 kg

◆ Dependent upon the material of the gasket installed.

* US Patent Number 6,712,967 and foreign patents pending

DuoFLO[®] ASME Code Filter Housings

Minimized Dirty Fluid Chamber - the DuoFLO filter element extends to the top of the housing cover to significantly reduce the dirty fluid volume compared to conventional bag filter systems

3 Eye Nuts - eliminate the need for special tools and allows for quick and easy filter element installation and removal

Light weight cover - remains attached to the housing and pivots open to allow easy access for filter change-out. Can be rotated for ideal pivot orientation.

304 or 316L Construction - provides compatibility with a wide range of fluids. Shot blast exterior finish improves appearance and allows for easy cleaning

ASME Code - meets local and state design requirements for pressure vessels

Inlet Stand Pipe - directs fluid to the top of the filter housing and inlet channels of the DuoFLO filter element

Available Connections - include 2" ANSI flange (shown), 2" NPT, 2" DIN flange, or 2" BSPT_r to satisfy most common piping requirements

In-line Bottom Inlet & Outlet - provides easy and cost effective installation by reducing the complexity of the piping scheme. Both the inlet and outlet piping have 1/2" NPT connections for drains, sample ports, or pressure gauge installation.

1/4" NPT Connection - for easy vent valve or pressure gauge installation

O-Ring Housing Seal - to provide a positive seal between the housing and the cover when the system is in use

Double O-Ring Element Seal - Seals the DuoFLO filter element to the top of the stand pipe (inlet) ensuring no by-pass

Support Basket - Full Support of the filter element ensures filter integrity even under the most demanding conditions. Eliminates media stretching which can open the media pores and allow larger particles to pass.

Dished Bottom - drains the clean liquid to the housing outlet for better product recovery and cleaner system operation

Optional Legs (shown below) - Adjustable legs can accommodate an inlet/outlet centerline height adjustment of up to 11 inches



DuoFLO® Filter Housing Dimensions

DuoFLO AMSE Code Model Housing							
Filter Size	Dimensions (Inches/cm)						
	A	B	C		D		E
			Flange	Thread	Max.	Min.	
1DF1	35/89	20/51	13/33.2	11 1/2/29.2	15/38.1	4/10.2	10 1/2 / 26.7
1DF2	63/160	34/87					

DuoFLO DFN Model Housing								
Filter Size	Dimensions (Inches/cm)							
	A		B		C		D	
	Inches	cm	Inches	cm	Inches	cm	Inches	cm
1DFN1	29 1/2	74.9	40	101.6	12	30.5	5	12.7
1DFN2	43 3/4	111.1	68 1/4	173	12	30.5		

DuoFLO Filter Piping Systems

The inline bottom inlet and outlet connections offer tremendous flexibility in manifolding the housings for series or parallel filtration. This concept allows for enhanced adaptability in achieving both short and long term flow and process requirements. Manifold piping systems (with and without valves) are available for installing DuoFLO housings in duplex, triplex, and quadplex configurations. Consult factory for more details.

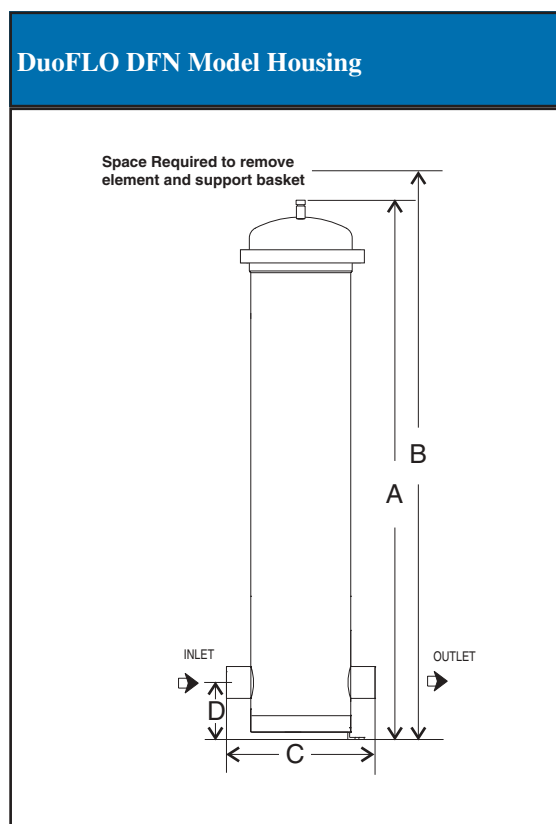
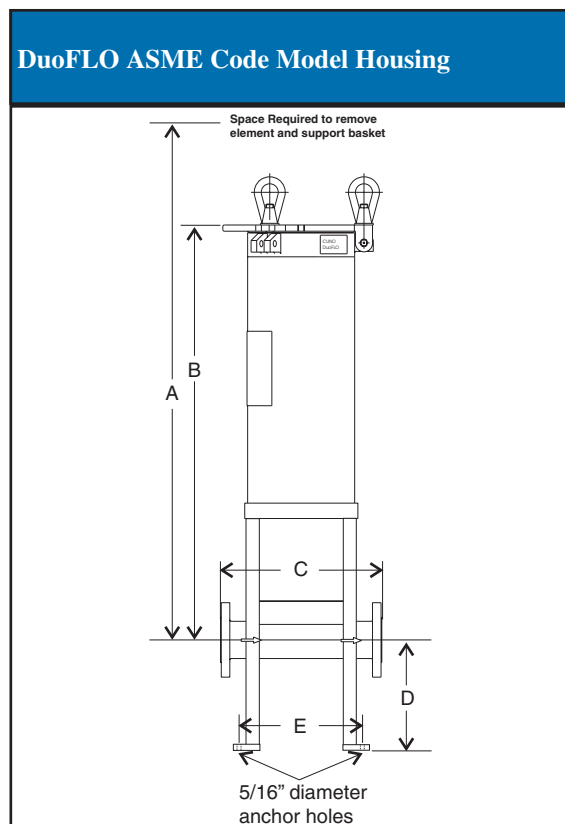

DuoFLO® Filter System Accessories

The following accessories are available for use with the DuoFLO filter system:

DuoFLO Element Installation Tool



Element Insertion Tool (Part # 60300-31): Constructed from 316 stainless steel, this tool facilitates insertion of DuoFLO elements into the support basket. The tool is designed with curved ends to ensure no damage is done when inserted into the element.

Element Removal Tool (Part # 74132-31): Constructed from 316 stainless steel, this tool facilitates removal of DuoFLO elements from the support basket. The tool is designed with an easy-to grip handle and locking tabs for proper support of element.

Element Hold Down Spring (Part # 64254-31): Constructed from 316 stainless steel, this spring assembly ensures the DuoFLO element is properly seated in side entry housings to prevent fluid bypass.

Magnet Assembly (Part # 60376-01): Constructed using 12,000 gauss strength magnets inserted into a 304 / 304 L Stainless steel tube, this magnet assembly provides for improved capture of metallic fines from fluid streams. This assembly is designed for easy insertion and removal and is fully supported when inserted into a DuoFLO element.

DuoFLO Element Hold Down Spring



DuoFLO Magnet

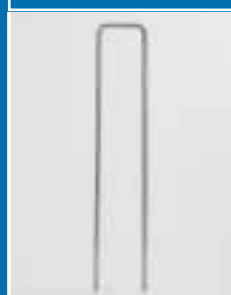

DuoFLO Element Removal Tool



DuoFLO® Filter Applications

Coatings	Electrodeposition Trade Paint Can Coatings Dispersions	Paper Coatings Adhesives Automotive Paint Architectural Paint	Printing Ink Resins Coil Coatings
Industrial	Parts Washing Pulp & Paper Cooling Water	Ground Water Waste Water Hydraulic Fluids	Lubricants Machine Tool Coolants Transformer Oil
Chemical	Acids Chemicals Process Water Alcohols Glycols	Fuels Catalyst Recovery Resins Alkalines Esters	Silicones Aerosol Products Mineral Oil Waxes Solvents
Petrochemicals	Fuel Additives Glycols Lube Oils	Distillation Enhanced Oil Recovery Amines	Fuels Injection Fluids
Food & Beverage	Vegetable Oil Syrups Edible Oils Soft Drinks Wine Spirits	Fruit Juice Beer Honey High Fructose Corn Syrup Vinegar	Liquid Sugar Bottled Water Gelatin Ready to Drink Tea Sports Drinks
Pharmaceutical	Catalyst Recovery Vitamin Extracts Bulk Pharmaceutical Chemicals OTC Solutions	Solvents Active Pharmaceutical Ingredients Carbon Removal	Water Systems Ophthalmics Lotions
Electronics	Etching Baths Process Water / RO Prefiltration	CD's / DVD's Photochemicals	Solvents Printed Circuit Manufacturing
Water Treatment	Cooling Water Process Water	Well Water Ground Water	Waste Water RO Prefiltration

DuoFLO® Filter Support Basket

CUNO offers a complete line of DuoFLO 316 stainless steel support baskets (many available in 316 L S.S.) for use in existing bag filter housings or in the DuoFLO filter housing. The DuoFLO element utilizes a unique basket for proper element support. The DuoFLO filter basket has two concentric stainless steel cylinders to support both the inner and outer filter element sleeves. This unique design ensures media integrity and consistent effluent quality. DuoFLO baskets include the optimum combination of strength and open area to provide proper media support, excellent flow characteristics, and minimal pressure drop.



The DuoFLO filter support basket ordering guide (below) cross references the competitive filter bag housing manufacturer and model to the correct DuoFLO support basket needed to upgrade to the DuoFLO filter element.

DuoFLO Filter Support Basket Ordering Guide (contact Factory for manufacturer models not listed)								
Existing Bag Filter Housing					Cuno Basket Information			
MFG	Model	# of Bags	Inlet Entry***	Size	Adapter Part #	Basket Gasket Part #	Basket Part # (316 SS)	Basket Part # (316L SS)
Filtrek	BMB	1 - 17	Side	#2	N/A	N/A	60382-35	N/A
FSI	FS - 85 & Up	1 - 24	Side	#2	N/A	N/A	60382-38****	N/A
FSI	FSP - 40	1	Side	#1	N/A	N/A	60382-32****	N/A
FSI	FSP - 85 & Up	1 - 24	Side	#2	N/A	N/A	60382-31****	60382-39
Filtration Systems	112	1	Over the top	#1	60343-31	N/A	60382-32	N/A
Filtration Systems	122	1	Over the top	#2	60343-31	N/A	60382-31	60382-39
GAF/AFFCO	RB(1,2 or 4)	1 - 4	Over the top	#1	60339-31xx*	N/A	60382-32	N/A
GAF/AFFCO	RB(1,2 or 4) L	1 - 4	Over the top	#2	60339-31xx*	N/A	60382-31	60382-39
GAF/AFFCO	RB1 SE	1	Side	#1	N/A	60334-3x442**	60382-34	N/A
GAF/AFFCO	RB1 L-SE	1	Side	#2	N/A	60334-3x442**	60382-33	N/A
GAF/AFFCO	RB(2 - 12)C2L	2 - 12	Side	#2	N/A	60334-3x442**	60382-33	N/A
Hayward	POLYLINE FLT 4202	1	Side	#2	60362-31	N/A	60382-31	60382-39
Hayward	TOPLINE TBF 0101	1	Over the top	#1	N/A	N/A	60382-32	N/A
Hayward	TOPLINE TBF 0102	1	Over the top	#2	N/A	N/A	60382-31	60382-39
Hayward	MAXILINE MBF	3 - 24	Side	#2	N/A	N/A	60382-31	60382-39
Hayward	MAXILINE SEMB	3 - 24	Side	#2	N/A	N/A	60382-31	60382-39
Krystil Klear	M88302 (OEM)	1	Side	#2	60346-31	N/A	60382-31	60382-39
Krystil Klear	L8815	1	Side	#1	N/A	N/A	60382-32	N/A
Krystil Klear	L8830	1	Side	#2	N/A	N/A	60382-31	60382-39
Parker	SB1 or 4	1 or 4	Side	#1	60340-31xx*	N/A	60382-32	N/A
Parker	SB1 or 4	1 or 4	Side	#2	60340-31xx*	N/A	60382-31	60382-39
Rosedale	8 - 15	1	Side	#1	N/A	N/A	60382-36	N/A
Rosedale	D8 - 15 (Duplex)	2	Side	#1	N/A	N/A	60382-36	N/A
Rosedale	8 - 30	1	Side	#2	N/A	N/A	60382-35	N/A
Rosedale	D8 - 30 (Duplex)	2	Side	#2	N/A	N/A	60382-35	N/A
Rosedale	16 - 48	2 - 23	Side	#2	N/A	N/A	60382-37	N/A
Strainrite	U FI-180	1 - 12	Side	#2	N/A	N/A	60382-31	60382-39

* Adapter Part Number (includes gasket)		
Gasket	GAF/AFFCO	Parker
Nitrile	60339-31GA	60340-31GA
EPR	60339-31GB	60340-31GB
Viton	60339-31GC	60340-31GC
TEV	60339-31GD	60340-31GD

**Basket Gasket Part Number	
Gasket	Part Number
Nitrile	60334-36442
EPR	60334-37442
Viton	60334-38442
TEV	60334-39442

*** Hold down Spring (Part # 64254-31) required for all side entry one bag housings

**** Seal Ring & FSI installation tool (Part # 74132-31) required

DuoFLO® Filter Element Ordering Guide

Filter Designation	Nominal Removal Rating (Microns)	Material (Media/Plastic Components)	Element Length (inches)	Connection Style
DFG - DuoFLO Graded-Porosity	001 - 1µm	PP - Polypro/Polypro	1 - 14.3 nominal	C - Open (DuoFLO Housings)
	005 - 5µm	EE - Polyester/Polyester	2 - 27.8 nominal	
	010 - 10µm	EP - Polyester/Polypro		R - Closed (Standard Bag Housings)
	025 - 25µm	FE - Polyester/Polyester**		
	050 - 50µm			
	100 - 100µm			
200* - 200µm				

* Available in single layer polyester material (Code EE) only

** 21CFR Materials, available in 1, 5, and 10µm only

DuoFLO AMSE Code Filter Housing Ordering Guide

Number Around	DuoFLO	Size	Housing Material	Connection Type	Support Legs	Gasket Material
1 = 1 Around	DF	1 = #1 Size	B = 304 SS	1 = 2" ANSI Flange	L = Legs*	GA = Nitrile**
		2 = #2 Size	C = 316L SS	2 = 2" NPT	N = No legs	GB = EPR
				3 = 2" DIN Flange		GC = Viton
				4 = 2" BSPT _r		

* Housing Legs (when ordered separately) 98848-01 ** Limits housing operating temperature to 250°F (121°C)

DuoFLO DFN Filter Housing Ordering Guide

Number Around	DuoFLO	Size	Housing Material	Connection Type	Support Legs	Gasket Materials
1 = 1 Around	DFN	1 = #1 Size	B = 304 SS	2 = 2" NPT	C - Mounting Clips	GA - Nitrile
		2 = #2 Size	C = 316L SS			GB - EPR
						GC - Viton

DuoFLO Filter Accessories

DuoFLO Element Installation Tool
Part # 60300-31



DuoFLO Magnet
Part # 60376-01

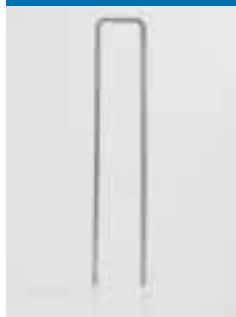

DuoFLO Element Removal Tool
Part # 74132-31



DuoFLO Element Hold Down Spring
Part # 64254-31



Filter Cartridge Benefits... Filter Bag Economy

Filter Cartridge Benefit	DuoFLO® Element	Standard Bag Filter
High Dirt Holding Capacity	<input checked="" type="checkbox"/> Yes	No
Rigid construction provided by the media or additional support components (i.e. cage and core)	<input checked="" type="checkbox"/> Yes	No
Installation/Removal convenience – ease of use	<input checked="" type="checkbox"/> Yes	No
Predictable retention even under elevated differential pressure	<input checked="" type="checkbox"/> Yes	No
Reduced hold-up volume	<input checked="" type="checkbox"/> Yes	No

WARRANTY

Seller warrants its equipment against defects in workmanship and material for a period of 12 months from date of shipment from the factory under normal use and service and otherwise when such equipment is used in accordance with instructions furnished by Seller and for purposes disclosed in writing at the time of purchase, if any. Any unauthorized alteration or modification of the equipment by Buyer will void this warranty. Seller's liability under this warranty shall be limited to the replacement or repair, F.O.B. point of manufacture, of any defective equipment or part which, having been returned to the factory, transportation charges prepaid, has been inspected and determined by the Seller to be defective. THIS WARRANTY IS IN LIEU OF ANY OTHER WARRANTY, EITHER EXPRESSED OR IMPLIED, AS TO DESCRIPTION, QUALITY, MERCHANTABILITY, FITNESS FOR ANY PARTICULAR PURPOSE OR USE, OR ANY OTHER MATTER. Under no circumstances shall Seller be liable to Buyer or any third party for any loss of profits or other direct or indirect costs, expenses, losses or consequential damages arising out of or as a result of any defects in or failure of its products or any part or parts thereof or arising out of or as a result of parts or components incorporated in Seller's equipment but not supplied by the Seller.

Your Local CUNO Distributor is:



a 3M company

CUNO Filtration Asia Pte Ltd
2A Tuas Avenue 12
Singapore 693023

CUNO Pacific Pty Ltd
140 Sunnyholt Road
Blacktown, NSW 2148
Australia

CUNO Latina Ltda
Rua Amf Do Brasil 251
18120 Mairinque-Sp
Brazil

Cuno Filtration Shanghai Co, Ltd
No. 2 Xin Miao San Rd,
Xin Miao Town,
Song Jiang District,
Shanghai, China. 201612

CUNO K.K.
Hodogaya Station
Building 6F
1-7 Iwai-cho, Hodogaya-ku
Yokohama 240 Japan

CUNO Ltd
21 Woking Business Park
Albert Drive
Woking, Surrey GU215JY
United Kingdom

Cuno Incorporated

400 Research Parkway
Meriden, CT 06450, U.S.A.

Tel: (800) 243-6894
(203) 237-5541

Fax: (203) 630-4530
www.cuno.com